

Development of a Smart Sensing System for Road Performance Data Collection

DESIGN DOCUMENT

Sdmay20-32

PROSPER

Halil Ceylan

Ethan Young - Project Manager

Michael Petersen- Hardware

Shlok Singh - Network

Victor Guerra - Software

sdmay20-32@iastate.edu

<http://sdmay20-32.sd.ece.iastate.edu>

Revised: 10/6 v1

Executive Summary

Development Standards & Practices Used

- Kanban Agile development approach
- Data will be transmitted through http requests

List all standard circuit, hardware, software practices used in this project. List all the Engineering standards that apply to this project that were considered.

Summary of Requirements

- Create a on-board device that calculates road roughness (IRI)
- Additional features include taking weather/GPS Information
- Wirelessly communicates data to server/app accessible by phone
- Total cost of device <\$100 in order to outfit DoT vehicles

Applicable Courses from Iowa State University Curriculum

- CPRE 288
- CPRE 388
- EE 201
- EE 230
- COMS 227-228
- COMS 319
- PHYS 221

New Skills/Knowledge acquired that was not taught in courses

- Microcontroller programing
- cloud storage
- Sensor data reading
- On-the-fly Calculation on the cloud
- USB readings

Table of Contents

1 Introduction	4
1.1 Acknowledgement	4
1.2 Problem and Project Statement	4
1.3 Operational Environment	4
1.4 Requirements	4
1.5 Intended Users and Uses	4
1.6 Assumptions and Limitations	5
1.7 Expected End Product and Deliverables	5
2. Specifications and Analysis	5
2.1 Proposed Design	5
2.2 Design Analysis	6
2.3 Development Process	6
2.4 Design Plan	6
3. Statement of Work	6
3.1 Previous Work And Literature	6
3.2 Technology Considerations	7
3.3 Task Decomposition	7
3.4 Possible Risks And Risk Management	7
3.5 Project Proposed Milestones and Evaluation Criteria	7
3.6 Project Tracking Procedures	7
3.7 Expected Results and Validation	7
4. Project Timeline, Estimated Resources, and Challenges	8
4.1 Project Timeline	8
4.2 Feasibility Assessment	8
4.3 Personnel Effort Requirements	8
4.4 Other Resource Requirements	8
4.5 Financial Requirements	9
5. Testing and Implementation	9
5.1 Interface Specifications	9
5.2 Hardware and software	9

5.3	Functional Testing	9
5.4	Non-Functional Testing	9
5.5	Process	10
5.6	Results	10
6.	Closing Material	10
6.1	Conclusion	10
6.2	References	10
6.3	Appendices	10

List of figures/tables/symbols/definitions (This should be similar to the project plan)

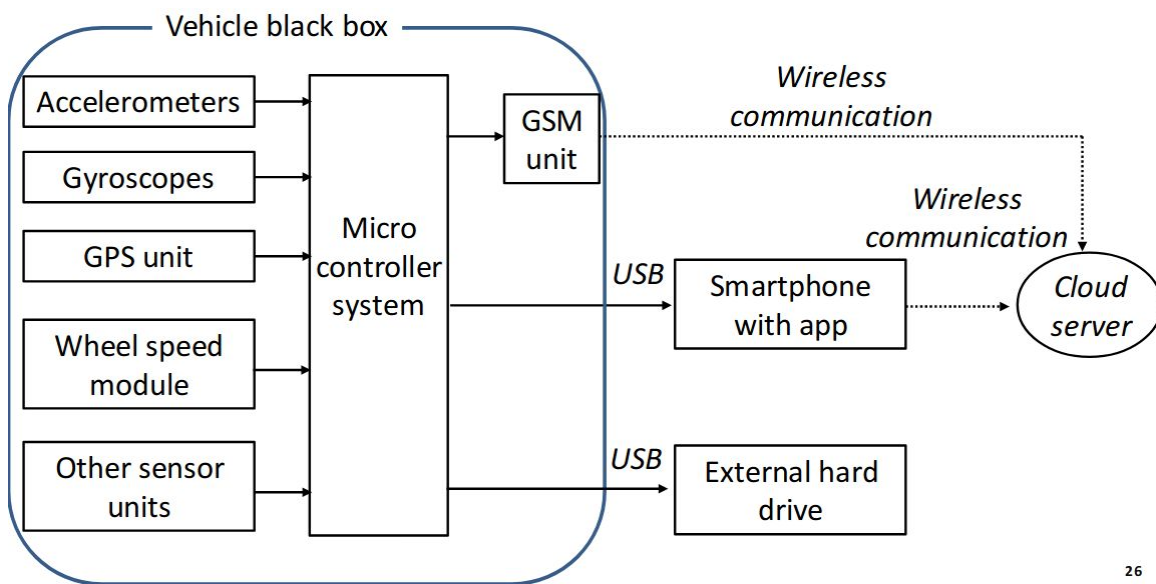

26

IRI - International Road Index

DOT - Department of Transportation

1 Introduction

1.1 ACKNOWLEDGEMENT

If a client, an organization, or an individual has contributed or will contribute significant assistance in the form of technical advice, equipment, financial aid, etc, an acknowledgement of this contribution shall be included in a separate section of the project plan.

Iowa State University and Halil Ceyan will be generously donating the financial aid required for this project.

1.2 PROBLEM AND PROJECT STATEMENT

– This is included so that the reader will have the correct conception of the problem and the solution approach upfront. Each shall be written in a non-technical manner that a lay person would understand.

– Consists of two components, each separated and clearly identified:

-General problem statement – defines the general problem area

-General solution approach – defines the proposed solution approach

-This section should also highlight the purpose of the project, what you are trying to do.

Explain what is driving this project. Why is it important?

Iowa DOT is wanting to see IRI calculations for all of the roadways in Iowa to see what roads are most important to fix first. To do this, they want an inexpensive solution rather than the expensive ones on the market currently.

/*Department of Transportation wants to take regular IRI readings of the many roads of Iowa. An inexpensive on-board device that can be outfitted on DoT's fleet of vehicles that works with minimal human input. The data must also be stored on a webapp, or remote server, and accessible by mobile phone.*/

Explain what the project is.

Our task for this project is to create a device that the Iowa DoT can outfit their fleet of vehicles with to take continuous data, throughout the year, on the roads within Iowa. In addition to this, our device can be used to take weather data, and other information while in-use.

Explain what you hope to accomplish. What are the outputs of the project?

The finished project will be a 'vehicle blackbox' that not only calculates the IRI of the road, but also takes weather data, and stores it on a remote server. The web server will also have a visualization of IRI readings across different roads as well as the other information.

1.3 OPERATIONAL ENVIRONMENT

– For any end product other than simply a calculation or simulation, it is essential to know the environment in which the end product will be used or to which it is expected to be exposed or experience. For example, will the end product be exposed to dusty conditions, extreme temperatures, or rain or other weather elements?

Although the ‘black box’ will be stored inside the vehicle, the device and the sensors within are required to work in the summer and winter. We will be assuming the vehicle has minimal heating and AC to insure the durability of our device. The black box will be fastened/secured, but will be exposed to light dust, and general wear and tear of driving conditions.

– This information is necessary in order to design an end product that can withstand the hazards that it is expected to encounter.

1.4 REQUIREMENTS

Functional Requirements

- International Road Index calculations
- GPS readings
- Web server to automatic data transfer
- Cell signal

Financial Requirements

- Minimize cost as much as possible.
- No maximum cost requirement to specifically follow, but device should be affordable for a fleet of vehicles.

Environmental/ Durability Requirements

- Weather resistant
- Shock proof since the black box will be on poor roads
- Low maintenance

Electrical Requirements

- Use power from the car

1.5 INTENDED USERS AND USES

The end users of the black box component will be any person operating a car in the Iowa DOT fleet. These users will not need to use the black box system as it will automatically upload the data to the cloud server. There will also be USB integration for smartphones that will allow for testing. This will be helpful to our team as well as any other team that may use our project at the Iowa DOT. There will also be backups on a USB hard drive/ SD card which can be used to get raw data off of the black box in the event a software failure occurs.

1.6 ASSUMPTIONS AND LIMITATIONS

Assumptions

- Maximum price should be around ~\$100
- Light-Duty webserver, only a few users viewing data, and only a few devices reporting data

The web server is expected to service a fleet of vehicles, but for the purpose of our project, a smaller scale is more practical to start out with. Future scaling of the server is expected, and on-board hardware is capable of such scaling.

Limitations

- Sensors must be contained inside the 'black box'
- Minimal human-input to start device
- On-board battery powered

Limitations are tied to design constraints. One obstacle that needs to be overcome is achieving accurate IRI readings while keeping the sensors within the box. Further research is needed to find ways to minimize error.

- Two separate lists, with a short justification as needed.
- Extremely important, as it can be one of the primary places where the client can go to determine if the end product will meet their needs.
- Examples of assumptions: The maximum number of simultaneous users/customers will be ten; Blue is the best background color and will be used; The end product will not be used outside the United States.
- Example of limitations: The end product shall be no larger than 5"x8"x3" (client requirement); The cost to produce the end product shall not exceed one hundred dollars (a market survey result); The system must operate at 120 or 220 volts and 50 or 60 Hertz (the most common household voltages worldwide).
- For limitations, include tests not performed, classes of users not included, budget/schedule limitations, geographical constraints, etc.

1.7 EXPECTED END PRODUCT AND DELIVERABLES

Our project will have two deliverables in order to meet the goals of the project. The first being the vehicle 'black box' housing a microcontroller and the sensors needed to take IRI measurements and other data. The second being our remote web server where the data will be stored and prepared visually. The goal of the server is to show the commercial capability of our device and the various features used in a real-world environment.

These tie in with the goals. What deliverables are necessary to meet the goals outlined in the introduction?

List the end product and any other items, along with a brief description, that will be delivered to the client prior to the end of the project.

- If the end product is to be commercialized, the description shall be of the commercialized end product.
- It shall be in the form of a technical product announcement, as opposed to a product advertisement, and shall not include a list of technical specifications.
- Any other items that will be delivered to the client shall also be included and described unless their definition and description are obvious.
- Examples might include a household power supply to eliminate the need for batteries, a user's manual, or other project reports.
- There shall be at least a one-paragraph description for each item to be delivered.
- Delivery dates shall also be specified.

2. Specifications and Analysis

2.1 PROPOSED DESIGN

Include any/all possible methods of approach to solving the problem:

- Discuss what you have done so far – what have you tried/implemented/tested, etc?

In the planning phase of our project, we have started by compiling research on possible microcontrollers, and sensors in order to find hardware best suited to our project. The microcontroller must have the proper amount of digital and analog input pins, as well as the appropriate power capabilities for our sensors. Currently we have figured out that there is a correlation between the z-axis acceleration and the IRI (Yuchuan, 1). This calculation is

$$\text{IRI} = \frac{1}{L} \int_0^L |Z_s - Z_u| dx,$$
 which is used on quarter-car IRI calculations. It requires knowledge about spring mass which could be a problem as all of us only had 2 weeks in physics on the subject.

- We want to know what you have done
- Approach methods should be inclusive of **functional and non-functional requirements** of the project, which can be repeated or just referred to in this section

If your project is relevant to any **standards** (e.g. IEEE standards, NIST standards) discuss the applicability of those standards here

2.2 DESIGN ANALYSIS

- Discuss what you did so far
- Did it work? Why or why not?
- What are your observations, thoughts, and ideas to modify or continue?
- If you have key results they may be included here or in the separate “Results” section

-Highlight the **strengths, weakness**, and your observations made on the proposed solution.

So far we have been researching microcontrollers, sensors, and IRI calculations.

2.3 DEVELOPMENT PROCESS

Discuss what development process you are following with a rationale for it – Waterfall, TDD, Agile. Note that this is not necessarily only for software projects. Development processes are applicable for all design projects.

For this project we will follow an Agile development process and more specifically a Kanban approach. This will help us to focus on only a few things at once to get them tested and working before trying to tackle new functional requirements. Kanban will be better for us rather than Scrum because with our busy schedules, we cannot afford to meet often. We will only be able to meet once maybe twice a week. GitLab has an Agile board included in its software that we will utilize for this process.

2.4 DESIGN PLAN

Describe a design plan with respect to use-cases within the context of requirements, modules in your design (dependency/concurrency of modules through a module diagram, interfaces, architectural overview), module constraints tied to requirements.'

One design constraint we have to work around is the accuracy of the IRI readings. Our sensor use is limited to the hardware capabilities of the Arduino microcontroller as well as the positioning of our sensors. A simpler IRI reading can be achieved from an accelerometer at the base at one of the wheels but leads itself due to inaccuracies due to asymmetry in the road. Working around these constraints, we will need to minimize error in other ways, and maximize the use of the sensors we have available to us. The accuracy of our IRI readings comes from the hardware we select as well as how we utilize them.

3. Statement of Work

3.1 PREVIOUS WORK AND LITERATURE

Include relevant background/literature review for the project

- If similar products exist in the market, describe what has already been done
- If you are following previous work, cite that and discuss the **advantages/shortcomings**
- Note that while you are not expected to “compete” with other existing products / research groups, you should be able to differentiate your project from what is available

Detail any similar products or research done on this topic previously. Please cite your sources and include them in your references. All figures must be captioned and referenced in your text.

A significant amount of research into IRI calculation and measurement is considered for this project. Because a primary goal of the black box is to come close to the design of much more

expensive systems, the required parameters must be understood and measured with accurate, affordable tools.

3.2 TECHNOLOGY CONSIDERATIONS

Highlight the strengths, weakness, and trade-offs made in technology available.

Discuss possible solutions and design alternatives

The blackbox will be built on some microcontroller with modular sensors. Because of the budgetary requirements of the design, the cheapest reasonable microcontroller was considered. Arduino systems were compared with Raspberry Pi systems. Although the Raspberry Pi is more full featured in terms of memory and compiler ability, various versions of the Arduino are cheaper with sufficient functionality.

3.3 TASK DECOMPOSITION

In order to solve the problem at hand, it helps to decompose it into multiple tasks and to understand interdependence among tasks.

The tasks breakdown will follow the project timeline. After a period of literature review, the microcontroller will be selected so that each other blackbox component can be researched and ensured compatible with the controller. During this time of device research, IRI measurement parameters will be known, and code will be built around them. Actual hardware interfacing and embedded design will be accomplished at the end of the first semester of the project once components have arrived.

3.4 POSSIBLE RISKS AND RISK MANAGEMENT

Include any concerns or details that may slow or hinder your plan as it is now. These may include anything to do with costs, materials, equipment, knowledge of area, accuracy issues, etc.

Although there is no hard budgetary limit on this project, minimizing cost is necessary. If the first choice of components is found to have incompatibilities or hardware failures, new components need to be ordered, increasing prototyping costs. Minimizing costs on a larger scale is more important, so comparing a selection of components will be beneficial.

3.5 PROJECT PROPOSED MILESTONES AND EVALUATION CRITERIA

What are some key milestones in your proposed project? Consider developing task-wise milestones. What tests will your group perform to confirm it works?

3.6 PROJECT TRACKING PROCEDURES

What will your group use to track progress throughout the course of this and next semester?

3.7 EXPECTED RESULTS AND VALIDATION

What is the desired outcome?

How will you confirm that your solutions work at a **High level**?

The desired end product will be a closed system device which sits inside any car and connects via USB to a power source to measure road roughness and transmit IRI data based on GPS location to an off-board storage location.

At the highest level, using the blackbox on roads of various roughnesses and comparing measurements with alternative measurement devices, such as the Roadroid app and laser truck rig, will give us a good idea of the effectiveness of our system.

4. Project Timeline, Estimated Resources, and Challenges

4.1 PROJECT TIMELINE

- A realistic, well-planned schedule is an essential component of every well-planned project
- Most scheduling errors occur as the result of either not properly identifying all of the necessary activities (tasks and/or subtasks) or not properly estimating the amount of effort required to correctly complete the activity
- A detailed schedule is needed as a part of the plan:
 - Start with a Gantt chart showing the tasks (that you developed in 3.3) and associated subtasks versus the proposed project calendar. The Gantt chart shall be referenced and summarized in the text.
 - Annotate the Gantt chart with when each project deliverable will be delivered
- Completely compatible with an Agile development cycle if that's your thing

How would you plan for the project to be completed in two semesters? Represent with appropriate charts and tables or other means.

Make sure to include at least a couple paragraphs discussing the timeline and why it is being proposed. Include details that distinguish between design details for present project version and later stages of project.

4.2 FEASIBILITY ASSESSMENT

Realistic projection of what the project will be. State foreseen challenges of the project.

4.3 PERSONNEL EFFORT REQUIREMENTS

Include a detailed estimate in the form of a table accompanied by a textual reference and explanation. This estimate shall be done on a task-by-task basis and should be based on the projected effort required to perform the task correctly and not just “X” hours per week for the number of weeks that the task is active

4.4 OTHER RESOURCE REQUIREMENTS

Identify the other resources aside from financial, such as parts and materials that are required to conduct the project.

4.5 FINANCIAL REQUIREMENTS

If relevant, include the total financial resources required to conduct the project.

5. Testing and Implementation

Testing is an **extremely** important component of most projects, whether it involves a circuit, a process, or a software library

Although the tooling is usually significantly different, the testing process is typically quite similar regardless of CprE, EE, or SE themed project:

1. Define the needed types of tests (unit testing for modules, integrity testing for interfaces, user-study for functional and non-functional requirements)
2. Define the individual items to be tested
3. Define, design, and develop the actual test cases
4. Determine the anticipated test results for each test case
5. Perform the actual tests
6. Evaluate the actual test results
7. Make the necessary changes to the product being tested
8. Perform any necessary

retesting

9. Document the entire testing process and its results

Include Functional and Non-Functional Testing, Modeling and Simulations, challenges you've determined.

5.1 INTERFACE SPECIFICATIONS

- Discuss any hardware/software interfacing that you are working on for testing your project

5.2 HARDWARE AND SOFTWARE

- Indicate any hardware and/or software used in the testing phase
- Provide brief, simple introductions for each to explain the usefulness of each

5.3 FUNCTIONAL TESTING

Examples include unit, integration, system, acceptance testing

5.4 NON-FUNCTIONAL TESTING

Testing for performance, security, usability, compatibility

5.5 PROCESS

- Explain how each method indicated in Section 2 was tested
- Flow diagram of the process if applicable (should be for most projects)

5.6 RESULTS

- List and explain any and all results obtained so far during the testing phase
 - - Include failures and successes
 - - Explain what you learned and how you are planning to change it as you progress with your project
 - - If you are including figures, please include captions and cite it in the text
- This part will likely need to be refined in your 492 semester where the majority of the implementation and testing work will take place
- Modeling and Simulation:** This could be logic analyzation, waveform outputs, block testing. 3D model renders, modeling graphs.
- List the **implementation Issues and Challenges.**

6. Closing Material

6.1 CONCLUSION

Summarize the work you have done so far. Briefly re-iterate your goals. Then, re-iterate the best plan of action (or solution) to achieving your goals and indicate why this surpasses all other possible solutions tested.

6.2 REFERENCES

This will likely be different than in project plan, since these will be technical references versus related work / market survey references. Do professional citation style(ex. IEEE).

Yuchuan Du, Chenglong Liu, Difei Wu, and Shengchuan Jiang, "Measurement of International Roughness Index by Using -Axis Accelerometers and GPS," *Mathematical Problems in Engineering*, vol. 2014, Article ID 928980, 10 pages, 2014.
<https://doi.org/10.1155/2014/928980>.

6.3 APPENDICES

Any additional information that would be helpful to the evaluation of your design document.

If you have any large graphs, tables, or similar that does not directly pertain to the problem but helps support it, include that here. This would also be a good area to include hardware/software manuals used. May include CAD files, circuit schematics, layout etc. PCB testing issues etc. Software bugs etc.